

MAX. OPERATING WEIGHT: 13339 kg (29407 lb) MAX. ENGINE POWER: 74 kW (99.5 hp)

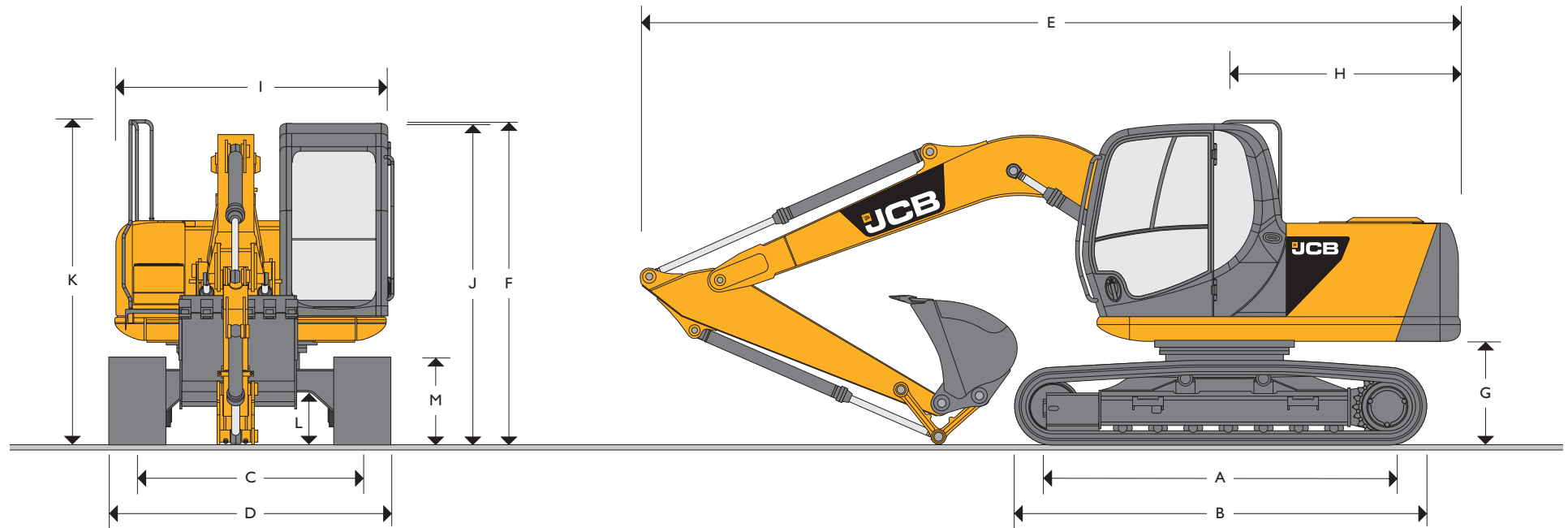

### STATIC DIMENSIONS

Dimensions in millimetres (ft-in)				Dimensions in millimetres (ft-in)	
A	Track length on ground			2580	(8-6)
B	Undercarriage overall length			3317	(10-11)
C	Track gauge			1990	(6-6)
D	Width over tracks (500mm trackshoes)			2490	(8-2)
D	Width over tracks (600mm trackshoes)			2590	(8-6)
D	Width over tracks (700mm trackshoes)			2690	(8-10)
Dipper lengths					
E	1.95m (6ft 5in)	2.25m (7ft 5in)	2.8m* (9ft 2in)	7357	(24-2)
F	2864 (9-5)	2864 (9-5)	2864 (9-5)	7392	(24-3)
G	Counterweight clearance			905	(3-0)
H	Tail swing radius			2135	(7-0)
I	Width of superstructure			2410	(7-11)
J	Height over cab			2839	(9-4)
K	Height over grab rail			2864	(9-5)
L	Ground clearance			464	(1-6)
M	Track height			767	(2-6)

\*Machine in transport position



## ENGINE

<b>Model</b>	JCB Dieslemax 444 TCA-74 EU Stage IIIA, EPA Tier 3 compliant.
<b>Type</b>	Water cooled, 4-stroke, 4-cylinder in-line, common rail direct injection, turbocharged intercooled diesel.
<b>Rated power (ISO 14899 (SAE J1995))</b>	74.2kW (99.5hp) at 2200rpm.
<b>Piston Displacement</b>	4.399 litres (1.16 UK gal).
<b>Injection</b>	Mechanical governor with electronic control.
<b>Air Filtration</b>	Dry element with secondary safety element and in cab warning indicator.
<b>Cooling</b>	Large capacity radiator.
<b>Starting system</b>	24 volt – 4kW.
<b>Batteries</b>	2 x 12 volt Heavy Duty.
<b>Alternator</b>	24 volt 55 amp.
<b>Refuelling pump</b>	Electric type.

## SWING SYSTEM

<b>Swing motor</b>	Axial piston type.
<b>Swing brake</b>	Hydraulic braking plus automatic spring applied disc type parking brake.
<b>Final drive</b>	Planetary reduction.
<b>Swing speed</b>	11.5 rpm.
<b>Swing gear</b>	Large diameter, internally toothed fully sealed grease bath lubricated.
<b>Swing lock</b>	Multi position switchable brake.

## UNDERCARRIAGE

<b>Construction</b>	Fully welded, "X" frame type with central bellyguarding and sloping sidemembers with dirt relief holes under top rollers.
<b>Recovery point</b>	Front and rear.
<b>Upper &amp; lower rollers</b>	Heat treated, sealed and lubricated.
<b>Track adjustment</b>	Grease cylinder type.
<b>Track type</b>	Sealed and lubricated.
<b>Track idler</b>	Sealed and lubricated, with spring cushioned recoil.
<b>Track shoes</b>	500mm (20in.) triple grouser 600mm (24in.) triple grouser 700mm (28in.) triple grouser
<b>Rollers and Shoes (each side)</b>	Upper rollers 1 Lower rollers 6 Track shoes 41

## HYDRAULIC SYSTEM

A variable flow load sensing system with flow on demand, variable power output and servo operated, multi-function open centre control. Machine auto warm up standard – maximises performance in cold conditions.

**Pumps**

Main pumps	2 variable displacement axial piston type.
Maximum flow	2 x 128 L/min (2 x 28 UK gpm).
Servo pump	Gear type.
Maximum flow	20 L/min (4 UK gpm).

**Control valve**

A combined four and five spool control valve with auxiliary service spool as standard. When required twin pump flow is combined to boom, dipper and bucket services for greater speed and efficiency.

**Relief valve settings**

Boom/Arm/Bucket	318 bar (4610lb/sq.in)
With power boost	343 bar (4975lb/sq.in)
Swing circuit	279 bar (4045lb/sq.in)
Travel circuit	343 bar (4975lb/sq.in)
Pilot control	40 bar (569lb/sq.in)

A separate Cushion Control valve in the servo system provides cushioning of the boom and dipper spools selection and quick warm-up of the servo system.

**Hydraulic cylinders**

Double acting type, with bolt-up end caps and hardened steel bearing bushes. End cushioning is fitted as standard on boom, dipper and bucket rams.

Optional hose burst check valves available for boom and dipper rams.

**Filtration**

The hydraulic components are protected by the highest standard of filtration to ensure long hydraulic fluid and component life.

<b>In tank</b>	150 micron, suction strainer.
<b>Main return line</b>	10 micron, fibreform element.
<b>Plexus Bypass line</b>	1.5 micron, paper element.
<b>Pilot line</b>	10 micron, paper element.
<b>Hydraulic hammer return</b>	10 micron, reinforced microform element.

**Cooling**

Worldwide cooling is provided as part of a single face cooling pack, in conjunction with the engine water cooler.

## TRACK DRIVE

<b>Type</b>	Fully hydrostatic, three speed with autoshift between high and medium speed.
<b>Travel motors</b>	Variable swash axial piston type, fully guarded within undercarriage frame.
<b>Final drive</b>	Planetary reduction, bolt-on sprockets.
<b>Service brake</b>	Hydraulic counter balance valve to prevent overspeeding on gradients.
<b>Park brake</b>	Disc type, spring applied, automatic hydraulic release.
<b>Gradeability</b>	70% (35 deg) continuous.
<b>Travel speed</b>	High – 4.41 km/h (2.74 mph). Mid – 2.89 km/h (1.80 mph). Low – 2.25 km/h (1.40 mph).
<b>Tractive effort</b>	110kN (24729lb).

## EXCAVATOR END

Monoboam available along with a choice of dipper lengths to suit the requirements of reach, dig-depth, loadover height, tearouts and site versatility. Reserve strength is built into the fully welded structures for hydraulic hammer and other arduous operations. Fabricated bucket tipping links are provided with a choice of lift points. Strong, durable construction, large cross sections and multi plate fabrications to withstand high stress applications. The 4.4m (14ft 5in) boom is designed to ensure the optimum digging envelope when matched with the three dipper lengths. Low maintenance bronze alloy bushes with graphite plugs are fitted to boom base and boom to dipper pivots resulting in 1000 hour greasing intervals at these points.

## CAB

Excellent digging, loading and positioning visibility results from the careful design of front, side and roof lights. All screens are tinted to improve in cab conditions. Fully opening front screen is very smooth to operate and as the lower screen is stored within the top screen frame it makes complete front screen opening easy, fast and convenient. Fresh air ventilation available from opening door window, opening slot in front screen and fully opening front screen. Parallelogram wash wiper for upper screen ensuring good wiped area for maximum visibility. Wiper motor is fitted in the left hand side of the roof screen so as not to affect bucket visibility when loading. Optional lower screen wiper available. Fresh air ventilation and heater with windscreen demister. Infinitely variable blower speed, temperature and recirculation control, with optional climate control. Fully adjustable deluxe suspension seat with arm rest adjustment and backrest recline. Optional radio with digital tuner fitted into the roof lining for maximum protection. Conveniently placed radio mute button incorporated into lower console. 12v power point and mobile phone holder built into the right hand console. Courtesy light can be operated from ground level and is illuminated for five minutes or until switched off improving operator access at night. Cab mounted roller blind protects operator from suns' glare through front or top screens.

## AMS – ADVANCED MANAGEMENT SYSTEM

Four selectable working modes link the operators control movements with the engine and hydraulic systems to maximise productivity and efficiency.

- A (Auto)** Up to 100% engine power and 100% flow. Gives variable power and speed depending on the operator's input, matching the demand for output and efficiency to the job. Power boost is automatically activated in this mode should hard conditions be encountered. Auto idle cuts in after a period of inactivity (between 5 and 30 seconds as set by the operator)
- E (Economy)** 80% engine power. 95% of hydraulic flow maximises economy while maintaining excellent output.
- P (Precision)** 55% engine power. 90% of hydraulic flow for fine control of grading operations.
- L (Lifting)** 55% engine power. 63% of hydraulic flow with permanent power boost for maximum lifting power and control.

The Auto mode allows the AMS processor to select the optimum operational performance to match the demands of the job while the three alternative modes give precise matching of application when specific tasks are undertaken.

The adjustable position monitor mounted on the front right hand pillar of the cab gives the operator a constant read out of mode, tracking range, operating temperature and a host of other information, while retaining excellent visibility of the monitor and the job being carried out.

The required flow for hammer applications can be set and stored in the AMS memory and is automatically activated whenever the hammer pedal is depressed.

A maintenance indicator warns of imminent service needs, and all servicing and basic checks can be carried out using only the in cab display.

## CONTROLS

- Excavator** All servo lever operated to ISO control pattern, independently adjustable to the seat.
- Tracks** Individually servo operated by foot pedal or hand lever. Speed selection via joystick button.
- Auxiliary** Via servo operated foot pedal.
- Control isolation** Via gate lock lever at cab entrance or panel switch.
- Engine speed** Dial type throttle control plus servo lever mounted one-touch idle control or separate selectable auto-idle with adjustable time delay using AMS.
- Engine stop** Ignition key operated and separate shut-down button.
- Horn** Operated via servo lever mounted button.
- Optional blade control** Independent lever in cab.

## SERVICE CAPACITIES

	Litres	UK Gal
Fuel tank	253	55.6
Engine coolant	19.7	4.3
Engine oil	20.4	4.5
Swing reduction gear	2.2	0.5
Track reduction gear (each side)	2.1	0.46
Hydraulic system	124.0	27.3
Hydraulic tank	73.0	16.1

## WEIGHTS AND GROUND BEARING PRESSURES

Machine equipped with 4.4m Monoboom, 2.25m Dipper, Standard Excavating Bucket, operator and full fuel tank.

Shoe Width	Operating Weight	Bearing Pressure
500mm (20in.)	12242kg (26989lb)	0.43kg/sq. cm. (6.12lb/sq. in.)
600mm (24in.)	12420kg (27381lb)	0.36kg/sq. cm. (5.12lb/sq. in.)
700mm (28in.)	12597kg (27772lb)	0.32kg/sq. cm. (4.55lb/sq. in.)

## OPTIONAL BLADE

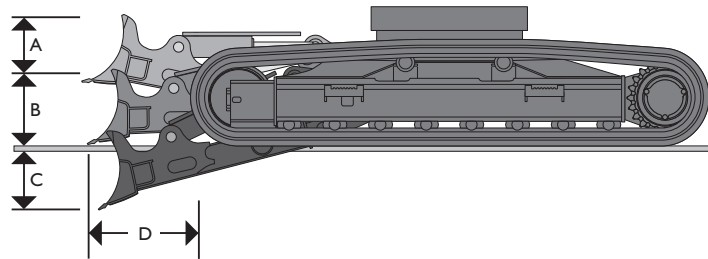

A	Blade height	mm (ft-in)	513 (1-8)
B	Blade lift above ground	mm (ft-in)	439 (1-5)
C	Blade cut below ground	mm (ft-in)	531 (1-9)
D	Blade forward of track	mm (ft-in)	551 (1-10)
	Dozer width – 500mm tracks	mm (ft-in)	2510 (8-3)
	Dozer width – 600mm tracks	mm (ft-in)	2610 (8-7)
	Dozer width – 700mm tracks	mm (ft-in)	2710 (8-11)
	<b>Additional weight with blade</b>		
	500mm tracks	kg (lb)	747 (1647)
	600mm tracks	kg (lb)	753 (1660)
	700mm tracks	kg (lb)	759 (1673)

## STANDARD / OPTIONAL EQUIPMENT

**Standard Equipment:** Engine fan guard; Cold start pre-heat; Auto engine warm up; Double element air cleaner; Heavy duty alternator; Electrics isolator; Heavy-duty batteries; Cab & engine soundproofing; Cab heater & screen demister; Tinted glass; Radio; Interior light; Coat hook; Cigarette lighter; Ashtray; Operator's storage shelf with cargo net; Removable floor mat; Windscreen wash/wipe; Plug-in power socket; Automatic power boost; Auto-idle; One-touch engine speed control; Hydraulic cushion control; Plexus hydraulic oil filtration; HSP pressure test points; Auxiliary pipework mounting brackets; Work lights – boom & mainframe mounted; Undercarriage belly guarding; Upper structure under covers; Swing system cover; External mirrors; Handrail & non slip walk ways; Quick connect engine oil drain pipe; Front screen blind; Quick connect fuel tank drain pipe.

**Optional Equipment:** Hose burst check valves & overload warning system; Tipping link mounted lift points; General purpose buckets; Ditching/grading buckets; Quickhitches; Hydraulic hammers; Auxiliary pipework (full and low flow); Climate control; Additional cab mounted worklights; Rotating beacon; Rain guard; Biodegradable oil; Air suspension seat with heated pad and lumbar support adjustment; Electric refuelling pump; Track guides; Lower screen wiper; Hot and cold climate hydraulic oils; Engine air precleaner; Widescore radiator, Backfilling/stabilising blade; Various track plate widths; Cab guard protection screens; Mesh screen guard; Seat belt; Fire extinguisher; Vandal cover kit; Travel alarm.

## BUCKET AND ARM COMBINATION

JCB Bucket	No Q/Hitch Fitted			Q/Hitch Fitted*		
	1.95m	2.25m	2.8m	1.95m	2.25m	2.8m
GP 500mm wide 0.235 cu.m (SAE heaped)	○	○	○	○	○	○
GP 600mm wide 0.315 cu.m (SAE heaped)	○	○	○	○	○	○
GP 700mm wide 0.39 cu.m (SAE heaped)	○	○	○	○	○	●
GP 750mm wide 0.43 cu.m (SAE heaped)	○	○	○	●	●	■
GP 800mm wide 0.47 cu.m (SAE heaped)	○	○	●	■	■	–
GP 900mm wide 0.55 cu.m (SAE heaped)	●	●	■	■	–	–
GP 1000mm wide 0.63 cu.m (SAE heaped)	■	■	–	–	–	–
GP 1100mm wide 0.715 cu.m (SAE heaped)	■	–	–	–	–	–

○ Material weight up to 1800kg/m<sup>3</sup> (1.35t/yd<sup>3</sup>)

● Material weight up to 1500kg/m<sup>3</sup> (1.13t/yd<sup>3</sup>)

■ Material weight up to 1200kg/m<sup>3</sup> (0.90t/yd<sup>3</sup>)

These recommendations are given as a guide based on typical operating conditions.

Please contact your distributor for the correct selection of buckets and attachments to suit the application.

\*Bucket capacity using JCB quickhitch only.

## WORKING RANGE

Boom length: 4.40m (14ft 5in)		
Dipper length:		1.95m (6ft 5in)
A	Maximum digging reach	mm (ft-in) 7547 (24-9)
B	Maximum digging reach (on ground)	mm (ft-in) 7324 (24-0)
C	Maximum digging depth	mm (ft-in) 4375 (14-4)
D	Maximum digging height	mm (ft-in) 8505 (27-11)
E	Maximum dumping height	mm (ft-in) 6112 (20-1)
F	Maximum vertical wall cut depth	mm (ft-in) 4435 (14-7)
G	Minimum swing radius	mm (ft-in) 2136 (7-0)
	Bucket rotation	182°
	Maximum dipper tearout (ISO 6015)	kgf (lbf) 5546 (12227)
	Maximum bucket tearout (ISO 6015)	kgf (lbf) 9375 (20668)
Dipper length: 2.25m (7ft 5in)		
A	Maximum digging reach	mm (ft-in) 7822 (25-8)
B	Maximum digging reach (on ground)	mm (ft-in) 7669 (25-2)
C	Maximum digging depth	mm (ft-in) 5024 (16-6)
D	Maximum digging height	mm (ft-in) 8638 (28-4)
E	Maximum dumping height	mm (ft-in) 6331 (20-9)
F	Maximum vertical wall cut depth	mm (ft-in) 4715 (15-6)
G	Minimum swing radius	mm (ft-in) 2168 (7-1)
	Bucket rotation	182°
	Maximum dipper tearout (ISO 6015)	kgf (lbf) 5000 (11023)
	Maximum bucket tearout (ISO 6015)	kgf (lbf) 9375 (20668)
Dipper length: 2.80m (9ft 2in)		
A	Maximum digging reach	mm (ft-in) 8281 (27-2)
B	Maximum digging reach (on ground)	mm (ft-in) 8136 (26-8)
C	Maximum digging depth	mm (ft-in) 5571 (18-3)
D	Maximum digging height	mm (ft-in) 8843 (29-0)
E	Maximum dumping height	mm (ft-in) 6601 (21-8)
F	Maximum vertical wall cut depth	mm (ft-in) 5351 (17-7)
G	Minimum swing radius	mm (ft-in) 2558 (8-5)
	Bucket rotation	182°
	Maximum dipper tearout (ISO 6015)	kgf (lbf) 4825 (10637)
	Maximum bucket tearout (ISO 6015)	kgf (lbf) 9375 (20668)

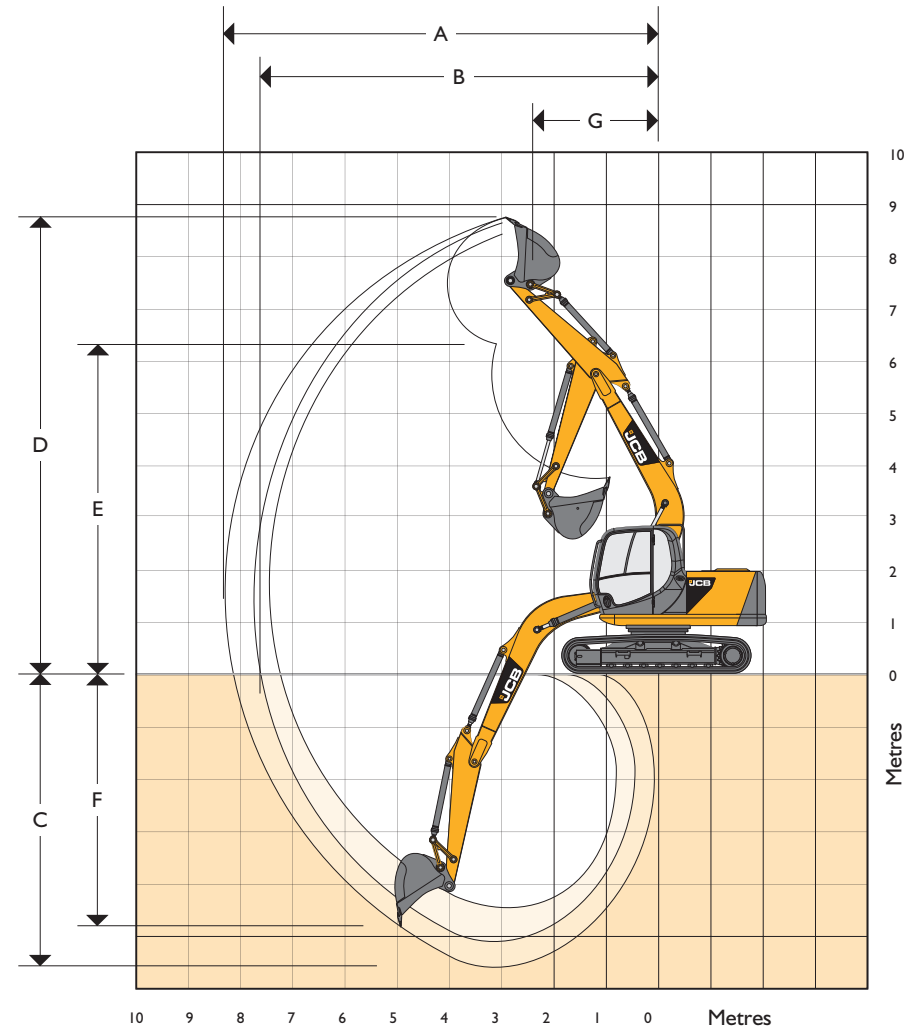

**LIFT CAPACITIES – Dipper Length: 1.95m (6ft 5in), 4.40m (14ft 5in) Monoboom, Trackshoes: 500mm (20in), No bucket.**
**JS115 MONO**

Reach	3m (9ft 10in)		4m (13ft 1in)		5m (16ft 5in)		6m (19ft 8in)		Capacity at Max Reach		
											mm
Load Point Ht.	kg	kg	kg	kg	kg	kg	kg	kg	kg	kg	mm
6.0m (19ft 8in)			3280*	3260					3020*	2830	4317
5.0m (16ft 5in)	3250*	3250*	3230*	3230*	2930	2210			2760	2070	5174
4.0m (13ft 1in)	4020*	4020*	3580*	3140	2900	2180			2290	1720	5730
3.0m (9ft 10in)	5350*	4670	4020	2970	2810	2100	2090	1550	2050	1520	6070
2.0m (6ft 7in)	6080	4240	3820	2780	2710	2000	2050	1510	1930	1420	6230
1.0m (3ft 3in)	5800	3990	3650	2630	2620	1920	2000	1470	1900	1390	6224
0m	5700	3910	3560	2540	2560	1860	1980	1440	1950	1430	6052
- 1.0m (- 4ft 11in)	5700	3900	3530	2510	2540	1840			2120	1550	5699
- 2.0m (- 6ft 7in)	5760	3950	3550	2530	2570	1870			2490	1810	5125
- 3.0m (- 9ft 10in)	5890	4070	3650	2630					3360	2430	4241

**LIFT CAPACITIES – Dipper Length: 2.25m (7ft 5in), 4.40m (14ft 5in) Monoboom, Trackshoes: 500mm (20in), No bucket.**
**JS115 MONO**

Reach	3m (9ft 10in)		4m (13ft 1in)		5m (16ft 5in)		6m (19ft 8in)		Capacity at Max Reach		
											mm
Load Point Ht.	kg	kg	kg	kg	kg	kg	kg	kg	kg	kg	mm
6.0m (19ft 8in)			2920*	2920*					2470*	2470*	4695
5.0m (16ft 5in)			2930*	2930*	2960	2230			2290*	1870	5492
4.0m (13ft 1in)	3580*	3580*	3290*	3170	2910	2190	2120	1580	2110	1570	6018
3.0m (9ft 10in)	4870*	4770	3910*	2990	2820	2100	2090	1550	1900	1400	6342
2.0m (6ft 7in)	6180	4320	3840	2800	2710	2000	2040	1500	1790	1310	6495
1.0m (3ft 3in)	5830	4010	3660	2630	2610	1900	1980	1450	1760	1280	6490
0m	5680	3880	3540	2520	2540	1830	1950	1410	1810	1310	6325
- 1.0m (- 4ft 11in)	5640	3850	3490	2470	2500	1800			1940	1410	5988
- 2.0m (- 6ft 7in)	5690	3890	3500	2480	2510	1810			2240	1620	5446
- 3.0m (- 9ft 10in)	5800	3990	3570	2550					2890	2090	4625

**LIFT CAPACITIES – Dipper Length: 2.80m (9ft 2in), 4.40m (14ft 5in) Monoboom, Trackshoes: 500mm (20in), No bucket.**
**JS115 MONO**

Reach	3m (9ft 10in)		4m (13ft 1in)		5m (16ft 5in)		6m (19ft 8in)		Capacity at Max Reach		
											mm
Load Point Ht.	kg	kg	kg	kg	kg	kg	kg	kg	kg	kg	mm
6.0m (19ft 8in)			2310*	2310*	2600*	2290			2150*	2050	5303
5.0m (16ft 5in)			2380*	2380*	2550*	2290	2080*	1630	2040*	1620	6018
4.0m (13ft 1in)			2760*	2760*	2730*	2240	2170	1620	1870	1390	6501
3.0m (9ft 10in)	3950*	3950*	3380*	3080	2860	2140	2110	1570	1700	1250	6802
2.0m (6ft 7in)	5470*	4510	3920	2860	2740	2020	2050	1510	1610	1170	6945
1.0m (3ft 3in)	5930	4100	3690	2660	2620	1910	1980	1440	1570	1140	6940
0m	5670	3870	3540	2510	2520	1820	1920	1390	1600	1150	6786
- 1.0m (- 4ft 11in)	5570	3780	3450	2430	2460	1760	1890	1360	1700	1220	6474
- 2.0m (- 6ft 7in)	5570	3770	3420	2410	2450	1750			1910	1370	5976
- 3.0m (- 9ft 10in)	5640	3840	3460	2440	2490	1780			2330	1680	5241



Lift capacity front and rear.



Lift capacity full circle.

**Notes:**

- For lifting capacity including bucket, subtract total weight of bucket or bucket and quickhitch from above values.
- Lifting capacities are based on ISO 10567, that is: 75% of minimum tipping load or 87% of hydraulic lift capacity, whichever is the less. Lifting capacities marked\* are based on hydraulic capacity.
- Lift capacities assume that the machine is on firm, level ground.
- Lift capacities may be limited by local regulations. Please refer to your dealer.

**LIFT CAPACITIES – Dipper Length: 1.95m (6ft 5in), 4.40m (14ft 5in) Monoboom, Trackshoes: 500mm (20in), No bucket.**
**JS115 MONO**

Reach	3m (9ft 10in)		4m (13ft 1in)		5m (16ft 5in)		6m (19ft 8in)		Capacity at Max Reach		
											mm
Load Point Ht.	kg	kg	kg	kg	kg	kg	kg	kg	kg	kg	mm
6.0m (19ft 8in)			3280*	3280*					3020*	3010	4317
5.0m (16ft 5in)	3250*	3250*	3230*	3230*	3210	2350			2780*	2210	5174
4.0m (13ft 1in)	4020*	4020*	3580*	3330	3170	2320			2520	1840	5730
3.0m (9ft 10in)	5350*	4960	4180*	3160	3090	2240	2310	1670	2270	1630	6070
2.0m (6ft 7in)	6670	4530	4190	2970	2990	2140	2270	1630	2140	1530	6230
1.0m (3ft 3in)	6230*	4280	4030	2820	2900	2060	2220	1580	2110	1500	6224
0m	6290	4200	3930	2730	2830	2000	2190	1560	2170	1540	6052
- 1.0m (- 4ft 11in)	6290	4190	3900	2700	2810	1980			2350	1670	5699
- 2.0m (- 6ft 7in)	6350	4240	3930	2720	2840	2010			2750	1950	5125
- 3.0m (- 9ft 10in)	5940*	4370	4030	2820					3700	2610	4241

**LIFT CAPACITIES – Dipper Length: 2.25m (7ft 5in), 4.40m (14ft 5in) Monoboom, Trackshoes: 500mm (20in), No bucket.**
**JS115 MONO**

Reach	3m (9ft 10in)		4m (13ft 1in)		5m (16ft 5in)		6m (19ft 8in)		Capacity at Max Reach		
											mm
Load Point Ht.	kg	kg	kg	kg	kg	kg	kg	kg	kg	kg	mm
6.0m (19ft 8in)			2920*	2920*					2470*	2470*	4695
5.0m (16ft 5in)			2930*	2930*	3010*	2370			2290*	2000*	5492
4.0m (13ft 1in)	3580*	3580*	3290*	3290*	3140*	2330	2310*	1690	2230	1680	6018
3.0m (9ft 10in)	4870*	4870*	3910*	3190	3090	2240	2310	1660	2100	1510	6342
2.0m (6ft 7in)	6360*	4610	4210	2990	2980	2140	2260	1610	1990	1420	6495
1.0m (3ft 3in)	6420	4300	4030	2820	2880	2040	2200	1560	1960	1390	6490
0m	6270	4170	3910	2710	2810	1980	2160	1530	2010	1420	6325
- 1.0m (- 4ft 11in)	6230	4140	3870	2670	2780	1940			2160	1520	5988
- 2.0m (- 6ft 7in)	6270	4180	3870	2670	2790	1950			2480	1750	5446
- 3.0m (- 9ft 10in)	6330*	4280	3950	2740					3200	2250	4625

**LIFT CAPACITIES – Dipper Length: 2.80m (9ft 2in), 4.40m (14ft 5in) Monoboom, Trackshoes: 500mm (20in), No bucket.**
**JS115 MONO**

Reach	3m (9ft 10in)		4m (13ft 1in)		5m (16ft 5in)		6m (19ft 8in)		Capacity at Max Reach		
											mm
Load Point Ht.	kg	kg	kg	kg	kg	kg	kg	kg	kg	kg	mm
6.0m (19ft 8in)			2310*	2310*	2600*	2440*			2150*	2150*	5303
5.0m (16ft 5in)			2380*	2380*	2550*	2440*	2080*	1750	2040*	1740	6018
4.0m (13ft 1in)			2760*	2760*	2730*	2380	2380	1730	2010*	1490	6501
3.0m (9ft 10in)	3950*	3950*	3380*	3270	3070*	2280	2330	1680	1880	1350	6802
2.0m (6ft 7in)	5470*	4800	4140*	3050	3010	2160	2260	1620	1790	1260	6945
1.0m (3ft 3in)	6520	4390	4070	2850	2890	2050	2200	1560	1750	1230	6940
0m	6260	4160	3910	2700	2800	1960	2140	1500	1790	1250	6786
- 1.0m (- 4ft 11in)	6160	4070	3820	2620	2740	1900	2110	1470	1900	1320	6474
- 2.0m (- 6ft 7in)	6160	4060	3800	2600	2720	1819			2120	1480	5976
- 3.0m (- 9ft 10in)	6230	4130	3840	2640	2760	1930			2590	1810	5241



Lift capacity front and rear.



Lift capacity full circle.

**Notes:**

- For lifting capacity including bucket, subtract total weight of bucket or bucket and quickhitch from above values.
- Lifting capacities are based on ISO 10567, that is: 75% of minimum tipping load or 87% of hydraulic lift capacity, whichever is the less. Lifting capacities marked\* are based on hydraulic capacity.
- Lift capacities assume that the machine is on firm, level ground.
- Lift capacities may be limited by local regulations. Please refer to your dealer.

## A GLOBAL COMMITMENT TO QUALITY

JCB's total commitment to its products and customers has helped it grow from a one-man business into Britain's largest privately owned manufacturer of backhoe loaders, crawler excavators, wheeled excavators, telescopic handlers, wheeled loaders, dump trucks, rough terrain fork lifts, industrial fork lifts, mini/midi excavators, skid steer loaders, tractors and compaction equipment.

By making constant and massive investments in the latest production technology, the JCB factories have become some of the most advanced in the world.

By leading the field in innovative research and design, extensive testing and stringent quality control, JCB machines have become renowned all over the world for performance, value and reliability.

And with a global sales and service network of more than 650 dealers and agents, we aim to deliver the best customer support in the industry.

Through setting the standards by which others are judged, JCB has become one of the world's most impressive success stories.



JCB Sales Limited, Rokester, Staffordshire ST14 5JP. Tel: 01889 590312. Fax: 01889 590588. Web: <http://www.jcb.com>

JCB reserves the right to change specifications without notice. Illustrations shown may include optional equipment and accessories. The JCB logo is a registered trademark of J C Bamford Excavators Ltd.



9999/5086 02/12 Issue 6